

— *fire* —
DESIGN
FOR LUXURY LIVING

ICON  FIRES





Fire Design For Luxury Living

Icon Fires set the standard for luxury bioethanol fireplaces with advanced levels of performance, functionality and refinement.

Icon Fires make a stylish addition to indoor and outdoor spaces. They open a world of creative scope to push the boundaries of fireplace design.

These flueless, environmentally friendly bioethanol fireplaces employ the latest technologies to achieve best efficiencies, vibrant flames and impressive heating performance. With burners and fireboxes to suit a variety of environments and all equipped with a unique heat and flame controllability feature, an industry first and exclusive to Icon Fires.

Visit www.iconfires.com for additional resources to help plan your Icon Fires fireplace.



About Bioethanol Fires

Icon Fires are fuelled with bioethanol. Bioethanol is a biofuel derived from plants including corn, wheat, barley and sugarcane. Bioethanol is a renewable energy source, with no odour and no harmful emissions. It creates a vibrant clean-burning flame with no harmful effects on the environment or the people using it.

Flueless fireplaces allow for endless installation possibilities. Architects, designers and home renovators around the world have embraced bioethanol fireplaces to achieve traditional and minimalist contemporary styles.





Commercial Range

Performance driven bioethanol fires ...

Icon Fires Commercial Range offers an Industry first 'performance driven' bioethanol fireplace for indoor and outdoor spaces.

The commercial range is designed for grand spaces delivering large dynamic flames with significant heat output.

The Commercial Linear Burners have controllable flame size achieving temperature control, fuel efficiency and longer burning times, an industry first and exclusive to Icon Fires. You can create a unique fireplace or install them into existing masonry fireplaces.

The Commercial Fireboxes used with the linear burners are available for inbuilt installations. The Commercial Fireboxes capture and direct the significant heat output efficiently into the room. Black interiors enhance the appearance of the flame. The Commercial Fireboxes are equally well suited for minimalist contemporary settings or traditional fireplaces with a mantelpiece

Commercial Range



IFMB614 Mid Burner 614

Dimensions:
H128mm x L624mm x D254mm
Cut out Sizes:
H105mm x L595mm x D230
Capacity: 7.7 litres
Consumption: avg 0.75lt/hr
Burning Time: Up to 10 hours
Performance: 6.5 kW/hr rating

IFLB914 Long Burner 914

Dimensions:
H128mm x L924mm x D254mm
Cut out Sizes:
H105mm x L895mm x D230
Capacity: 11.5 liters
Consumption: avg 0.9lt/hr
Burning Time: Up to 12 hours
Performance: 10 kW/hr rating

- High performance, clean-burning bioethanol burners.
- Flame and heat control.
- Durable 304 stainless steel construction.
- Twin Skin Top Tray supplied.
- Suitable for custom settings and existing masonry fireplaces.
- Suits indoor and outdoor use.
- All burners come with electronic pump for easy refueling.



CMFBCLASSIC Commercial Classic Firebox Complete with IFMB614 Burner

Dimensions:
H600mm x L900mm x D375mm
Fascia Finishes: ■ □
Capacity: 7.7 litres
Consumption: avg 0.75lt/hr
Burning Time: Up to 10 hours
Performance: 6.5 kW/hr rating

CMFBXL Commercial XL Firebox Complete with IFLB914 Burner

Dimensions:
H600mm x L1100mm x D375mm
Fascia Finishes: ■ □
Capacity: 11.5 liters
Consumption: avg 0.9lt/hr
Burning Time: Up to 12 hours
Performance: 10 kW/hr rating

- Supplied complete with a matching burner.
- Directional-Convection system.
- Choice of fascia: Black or Brushed Stainless Steel.
- Interior finish: Black.
- Suits indoor and outdoor use.

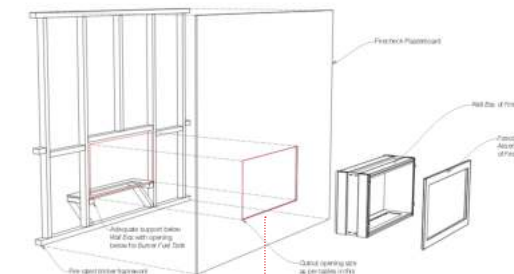

IMPORTANT
Insulation must be securely wrapped around the firebox body before placing inside opening

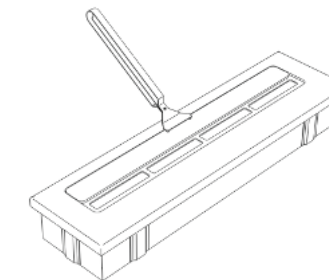

Flame height and heat control are a feature of all Icon Fires linear burners. Improving comfort and fuel efficiency.



Slimline Range

It's the attention to detail ...

The Slimline range offers the industry's longest linear burners that produce a stretched continuous flame for dramatic effect. All burners are designed for custom installations both indoor and outdoors.

Fine detail and quality finishes distinguish Slimline Burners. The unique mounting frame enables flush fitting into the surface. Elegant proportions and the brushed stainless steel accentuate the long continuous flame.

Complementing the Slimline Linear Burners are matching Fireboxes designed for inbuilt installations. Their shallow depth simplifies fitting into compact settings.

Black interiors enhance the flame's appearance. With a choice of brushed stainless steel or black fascias to finish off the setting.

Simple installation opens up endless positioning possibilities for Icon Fires Slimline Range.



Slimline Range



SB500 Slimline Burner

Dimensions:
H100mm x L545mm x D145mm
Cut Out Size:
H110mm x L530mm x D130mm
Capacity: 2.75 Litres
Consumption: avg 0.3 lt/hr
Burning Time: Up to 8 hours
Performance: 2.5 kW/hr rating



SB800 Slimline Burner

Dimensions:
H100mm x L845mm x D145mm
Cut Out Size:
H110mm x L830mm x D130mm
Capacity: 4.5 Litres
Consumption: avg 0.6 lt/hr
Burning Time: Up to 8 hours
Performance: 4.35 kW/hr rating

SB1100 Slimline Burner

Dimensions:
H100mm x L1145mm x D170mm
Cut Out Size:
H110mm x L1130mm x D155mm
Capacity: 6.25 Litres
Consumption: avg 0.9lt/hr
Burning Time: Up to 9 hours
Performance: 7.25 kW/hr rating

SB1400 Slimline Burner

Dimensions:
H100mm x L1445mm x D170mm
Cut Out Size:
H110mm x L1430mm x D155mm
Capacity: 8.15 Litres
Consumption: avg 1.0 lt/hr
Burning Time: Up to 9 hours
Performance: 9.5 kW/hr rating

- High efficiency, clean-burning bioethanol burners.
- Flame and heat control.
- Slender dimensions allow for compact installations.
- Brushed finish, 304 Stainless steel construction.
- Suitable for custom settings and existing masonry fireplaces.
- Suits indoor and outdoor use.
- All burners come with electric pump for easy refueling.

Slimline Burner Image
SB1400 has dual sliding plate, smaller models have single sliding plate



SFB1100 Slimline Firebox Complete with SB800 Burner

Dimensions:
H600mm x L1100mm x D315mm
Fascia Finishes: ■ □
Capacity: 4.5 Litres
Consumption: avg 0.6 lt/hr
Burning Time: Up to 8 hours
Performance: 4.35 kW/hr rating

SFB1350 Slimline Firebox Complete with SB1100 Burner

Dimensions:
H600mm x L1350mm x D315mm
Fascia Finishes: ■ □
Capacity: 6.25 Litres
Consumption: avg 0.9lt/hr
Burning Time: Up to 9 hours
Performance: 7.25 kW/hr rating

SFB1650 Slimline Firebox Complete with SB1400 Burner

Dimensions:
H600mm x L1650mm x D315mm
Fascia Finishes: ■ □
Capacity: 8.15 Litres
Consumption: avg 1.0 lt/hr
Burning Time: Up to 9 hours
Performance: 9.5 kW/hr rating

- Fireboxes in contemporary stretched linear formats.
- Supplied complete with a matching burner.
- Shallow depth simplifies installation.
- Choice of fascia: Black or Brushed Stainless Steel.
- Interior finish: Black.
- Suits indoor and outdoor use.

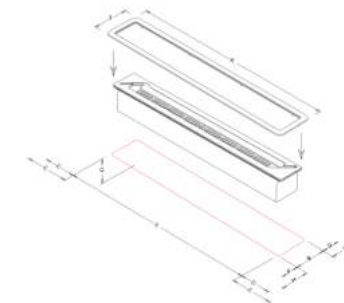

Slimline's unique Mounting Frame enables a clean, flush finish into the bench surface.

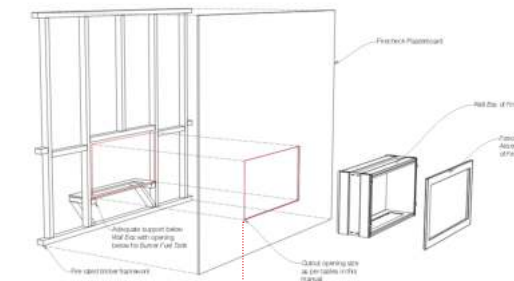

IMPORTANT →
Insulation must be securely wrapped around the firebox body before placing inside opening

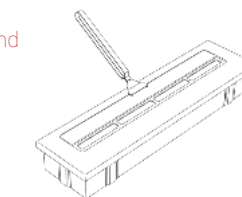

Flame height and heat control are a feature of all Icon Fires linear burners. Improving comfort and fuel efficiency.



Nero Wall Fires

It simply mounts on the wall ...

Mounting a fire setting onto an interior wall is an exciting new way to bring a decorative fire into a living space.

Nero Wall Fires hang from a simple to fit wall bracket. The slender proportions of the Slimline Burners allow for an unobtrusive installation with Nero projecting just 170mm off the wall.

Nero Wall Fires are available in three sizes to match the Slimline Burners in 800mm, 1100mm and 1400mm.



Flame stability, efficiency, fuel economy and heat output are all enhanced with the latest burner technologies employed across the Icon Fires range.

Heat output and flame effect can be controlled with all Icon Fires burners. An industry first and exclusive to Icon Fires for this style of burner.

Nero Wall Fires



- Supplied complete with matching burner.
- Choice of fascia: Black or Stainless Steel.
- Interior finish: Black.
- Suits indoor use only.

Nero 1150 Complete with SB800 BURNER

Dimensions:
H590mm x L1150mm x D170mm
Fascia Finishes: ■ □
Capacity: 4.5 Litres
Consumption: avg 0.6 lt/hr
Burning Time: Up to 8 hours
Performance: 4.35 kW/hr rating

Nero 1450 Complete with SB1100 BURNER

Dimensions:
H590mm x L1450mm x D195mm
Fascia Finishes: ■ □
Capacity: 6.25 Litres
Consumption: avg 0.9lt/hr
Burning Time: Up to 9 hours
Performance: 7.25 kW/hr rating

Nero 1750 Complete with SB1400 BURNER

Dimensions:
H590mm x L1750mm x D195mm
Fascia Finishes: ■ □
Capacity: 8.15 Litres
Consumption: avg 1.0 lt/hr
Burning Time: up to 9 hours
Performance: 9.5 kW/hr rating

DISCLAIMER*
Specifications are subject to change without notice.
Current specification documentation can be obtained from www.iconfires.com

For more information visit
www.iconfires.com
or contact us at info@iconfires.com

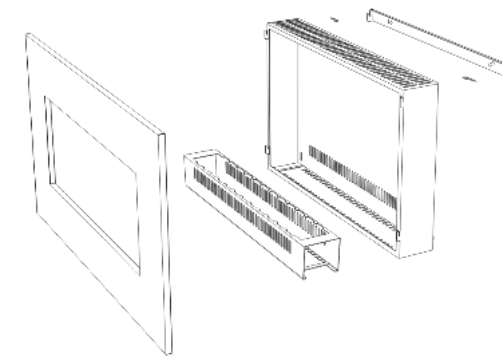

Slender proportions, minimal projection off the wall.

ICON  FIRES

www.iconfires.com